



**General Characteristics of MCD Series
High Stand Explosion Proof Industrial
Direct Drive Blowers**

The MCD Series motors come in two options totally enclosed and explosion proof. Can be used in industrial or commercial areas. For indoor or outdoor use. Used for cooling and high volume air movement. The blades are made of cast aluminum; the body and stand are made from 14 gauge steel. This product comes with the option of an acid resistant coating. For Safety the CPB Series are designed with spiral wire front and rear guards. Finished off with a baked enamel coating. The high and High Stand units have a 360° swivel. Explosion proof motors are Class 1, Div. 1, Group D and Class 2 Div. 1, Groups F & G. Single phase motors are field convertible 115V/230V. Three phase motors are field convertible 230V/460V. Motors are set to lower voltage at the factory unless a request is made at the time of order to set to the higher voltage. Note: products listed are custom built and subject to 100% cancellation/restocking charges. The MCD Series meets OSHA requirements. Imported to TPI specifications

**Product Applications of MCD Series
High Stand Explosion Proof Industrial
Direct Drive Blowers**

For industrial and commercial use. Used for cooling factories, shops, bakeries, loading docks, laundries, gymnasiums, warehouses, aircraft hangars, and virtually any place a high volume of air movement is required. For indoor and outdoor use.

**Warranty of MCD Series High Stand
Explosion Proof Industrial Direct Drive
Blowers**

Manufacturer's Warranty: 1 year.





Specific Characteristics of MCD Series High Stand Explosion Proof Industrial Direct Drive Blowers

Item #	Manufacturing #	Size Ø(In.)	CFM	Volts V	Amperes A	Phases Ph	HP	RPM	DB'S	Stand Type	Weight and Dimensions with Packaging	
											Lbs.	L,W,H In.
USHSG-001	MCD18-1/4-H	18	3050	115/230	2.25/1.13	1	1/4	1725	74	High Stand	105	34,25,40
USHSG-002	MCD18-1/4-H-3	18	3050	230/460	0.73/0.36	3	1/4	1725	74	High Stand	105	34,25,40
USHSG-003	MCD18-1/3-H	18	3450	115/230	2.97/1.49	1	1/3	1725	76	High Stand	107	34,25,40
USHSG-004	MCD18-1/3-H-3	18	3450	230/460	0.95/0.74	3	1/3	1725	76	High Stand	107	34,25,40
Item #	Manufacturing #	Size Ø(In.)	CFM	Volts V	Amperes A	Phases Ph	HP	RPM	DB'S	Stand Type	Weight and Dimensions with Packaging	
USHSG-005	MCD18-1-H	18	4600	115/230	9.01/4.5	1	1	1725	77	High Stand	235	34,25,40
USHSG-006	MCD18-1-H-3	18	4600	230/460	2.89/1.45	3	1	1725	77	High Stand	235	34,25,40
USHSG-007	MCD24-1/4-H	24	5200	115/230	2.25/1.13	1	1/4	1725	80	High Stand	235	34,31,43
USHSG-008	MCD24-1/4-H-3	24	5200	230/460	0.73/0.36	3	1/4	1725	80	High Stand	235	34,31,43
USHSG-009	MCD24-1/3-H	24	5300	115/230	2.97/1.49	1	1/3	1140	74	High Stand	255	34,31,43
USHSG-010	MCD24-1/3-H-3	24	5300	230/460	0.95/0.74	3	1/3	1140	74	High Stand	255	34,31,43
USHSG-011	MCD24-1/2-H	24	6000	115/230	4.5/2.25	1	1/2	1725	80	High Stand	245	34,31,43
USHSG-012	MCD24-1/2-H-3	24	6000	230/460	1.45/0.73	3	1/2	1725	80	High Stand	245	34,31,43
USHSG-013	MCD24-3/4-H	24	6900	115/230	6.76/3.38	1	3/4	1140	74	High Stand	265	34,31,43
USHSG-014	MCD24-3/4-H-3	24	6900	230/460	2.16/1.09	3	3/4	1140	74	High Stand	265	34,31,43
USHSG-015	MCD24-1-H	24	7400	115/230	9.01/4.5	1	1	1725	82	High Stand	255	34,31,43
USHSG-016	MCD24-1-H-3	24	7400	230/460	2.89/1.45	3	1	1725	82	High Stand	255	34,31,43
USHSG-017	MCD24-1 1/2-H	24	8200	115/230	13.5/6.76	1	1 1/2	1725	84	High Stand	260	34,31,43
USHSG-018	MCD24-1 1/2-H-3	24	8200	230/460	4.34/2.16	3	1 1/2	1725	84	High Stand	260	34,31,43
USHSG-019	MCD24-3-H-3	24	10500	230/460	8.68/4.34	3	3	1725	87	High Stand	275	34,31,43
USHSG-020	MCD30-1/3-H	30	6900	115/230	2.97/1.49	1	1/3	1140	80	High Stand	265	34,37,46
USHSG-021	MCD30-1/3-H-3	30	6900	230/460	0.95/0.74	3	1/3	1140	80	High Stand	265	34,37,46
USHSG-022	MCD30-1/2-H	30	8900	115/230	4.5/2.25	1	1/2	1725	86	High Stand	255	34,37,46
USHSG-023	MCD30-1/2-H-3	30	8900	230/460	1.45/0.73	3	1/2	1725	86	High Stand	255	34,37,46
USHSG-024	MCD30-3/4-H	30	10400	115/230	6.76/3.38	1	3/4	1140	80	High Stand	320	34,37,46
USHSG-025	MCD30-3/4-H-3	30	10400	230/460	2.16/1.09	3	3/4	1140	80	High Stand	320	34,37,46
USHSG-026	MCD30-1-H	30	11200	115/230	9.01/4.5	1	1	1140	81	High Stand	315	34,37,46
USHSG-027	MCD30-1-H-3	30	11200	230/460	2.89/1.45	3	1	1140	81	High Stand	315	34,37,46
USHSG-028	MCD30-1 1/2-H	30	12000	115/230	13.5/6.76	1	1 1/2	1725	92	High Stand	315	34,37,46
USHSG-029	MCD30-1 1/2-H-3	30	12000	230/460	4.34/2.16	3	1 1/2	1725	92	High Stand	315	34,37,46
USHSG-030	MCD30-2-H-3	30	14000	230/460	5.78/2.89	3	2	1140	84	High Stand	335	34,37,46
USHSG-031	MCD30-3-H-3	30	16000	230/460	8.68/4.34	3	3	1725	94	High Stand	330	34,37,46
USHSG-032	MCD36-1-H	36	13000	115/230	9.01/4.5	1	1	1140	82	High Stand	380	34,43,47
USHSG-033	MCD36-1-H-3	36	13000	230/460	2.89/1.45	3	1	1140	82	High Stand	380	34,43,47
USHSG-034	MCD36-1 1/2-H	36	14850	115/230	13.5/6.76	1	1 1/2	1725	88	High Stand	380	34,43,47
USHSG-035	MCD36-1 1/2-H-3	36	14850	230/460	4.34/2.16	3	1 1/2	1725	88	High Stand	380	34,43,47
USHSG-036	MCD36-2-H-3	36	17500	230/460	5.78/2.89	3	2	1140	82	High Stand	385	34,43,47
USHSG-037	MCD36-3-H-3	36	18500	230/460	8.68/4.34	3	3	1725	90	High Stand	395	34,43,47
USHSG-038	MCD36-5-H-3	36	23000	230/460	14.5/7.23	3	5	1725	94	High Stand	395	34,43,47
USHSG-039	MCD42-2-H-3	42	19500	230/460	5.78/2.89	3	2	1140	85	High Stand	570	34,49,50
USHSG-040	MCD42-5-H-3	42	27000	230/460	14.5/7.23	3	5	1725	98	High Stand	575	34,49,50
USHSG-041	MCD48-5-H-3	48	32000	230/460	14.5/7.23	3	5	1140	92	High Stand	715	34,55,63
USHSG-042	MCD48-7 1/2-H-3	48	37000	230/460	21.6/10.8	3	7 1/2	1140	105	High Stand	840	34,55,63
USHSG-043	MCD48-10-H-3	48	41000	230/460	28.9/14.5	3	10	1140	105	High Stand	895	34,55,63



Dimensions (In.) of MCD Series High Stand Explosion Proof Industrial Direct Drive Blowers

Series	Length A	Width B	Height C
USHSG-001 to 006	35"	23"	57"
USHSG-007 to 019	35"	29"	57"
USHSG-020 to 031	35"	35"	57"
USHSG-032 to 038	35"	41"	57"
USHSG-039 & 040	35"	47 1/2"	57"
USHSG-041 to 043	35"	53 1/2"	57"

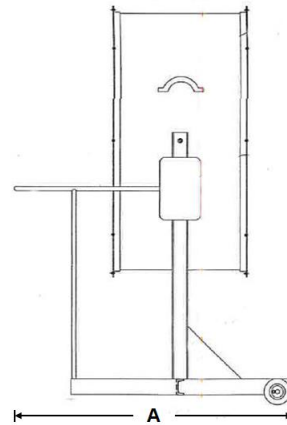
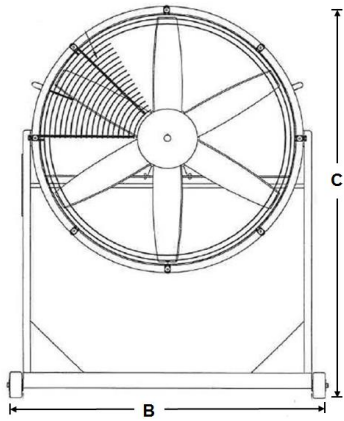



MCD Series High Stand Explosion Proof Industrial Direct Drive Blowers

Ratings Definitions

Class I: Equipment does not have surface operating temperature in excess of the ignition temperature of the specific gas or vapor.

Application Examples:

- Offshore and land based drilling rigs, petroleum exploration and testing facilities.
- Petroleum refineries, gasoline storage and dispensing areas.
- Industrial firms that use flammable liquids in dip tanks for parts cleaning or other operations.
- Petrochemical companies that manufacture chemicals from gas or oil.
- Dry cleaning facilities where vapors from cleaning fluids may be present.
- Aircraft hangers and fuel servicing areas.
- Utility gas plants and operations involving storage and handling of liquefied petroleum or natural gas.

Group C: Atmospheres such as but not limited to acetaldehyde, allyl alcohol, hydrogen sulfide, ethylene, carbon monoxide, or other gases or vapors of equivalent hazard.

Group D: Atmospheres such as but not limited to acetone, alcohol, gasoline, lacquer solvent vapors, natural gas, propane or other gases or vapors of equivalent hazard.

Class II: Equipment does not have surface temperature greater than the ignition temperature of the specified dust.

Application Examples:

- Coal preparation plants and other carbon handling or processing areas.
- Grain elevators, flour and feed mills.
- Plants which manufacture, use or store Magnesium or Aluminum powders.
- Plants that have chemical or metallurgical processes.
- Producers of starch products or candy.
- Spice grinding plants, sugar plants and cocoa plants.

Group E: Atmosphere containing combustible metal dust regardless of resistivity, or other combustible dust of similar hazard characteristics having resistivity of less than 10⁵ OHM- centimeter.

Group F: Atmosphere containing carbon black, charcoal, coal or coke dust.

Group G: Atmospheres containing combustible dust having resistivity of 10⁵ OHM- centimeter or greater.

Division I: A location in which ignitable concentrations of flammable material exist under normal operating conditions.

Division II: Locations in which flammable materials will normally be confined within closed containers and escape only in the case of accidental rupture, breakdown or during maintenance operations. Any equipment approved for Division I is automatically also approved for Division II.

ID	Author	Description Error	Description Update	Supervisor Name
V2	Marcela Roldán	Repeated Key	Product key is changed	Jessica Lorenzo